

# il Monoblocco ideal tipo Rimini - A

PROFILO CAPPOTTO DA 50 MM

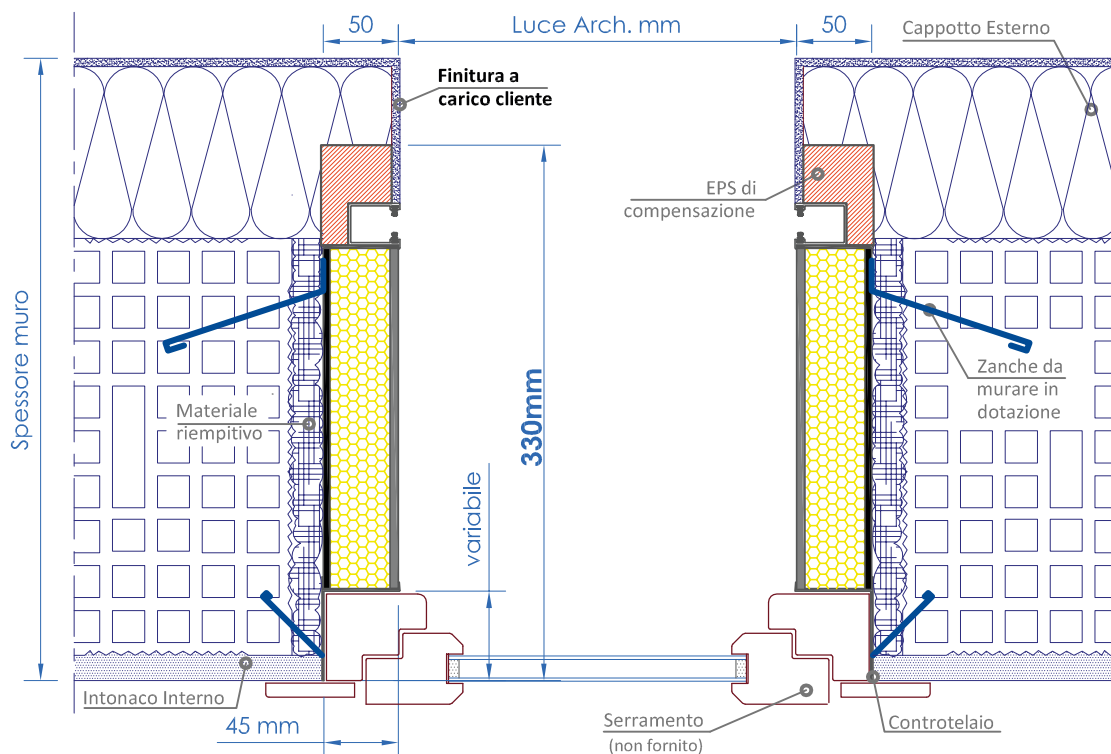

## PREDISPOSIZIONE FORO GREZZO

Manovra Manuale dx

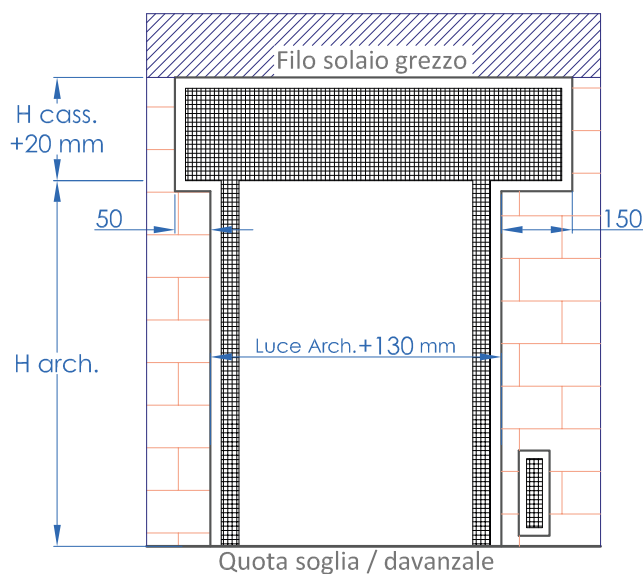

Manovra Motorizzata

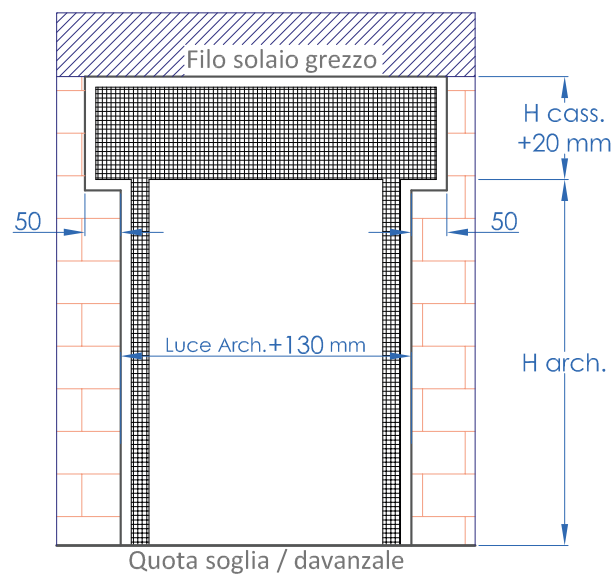

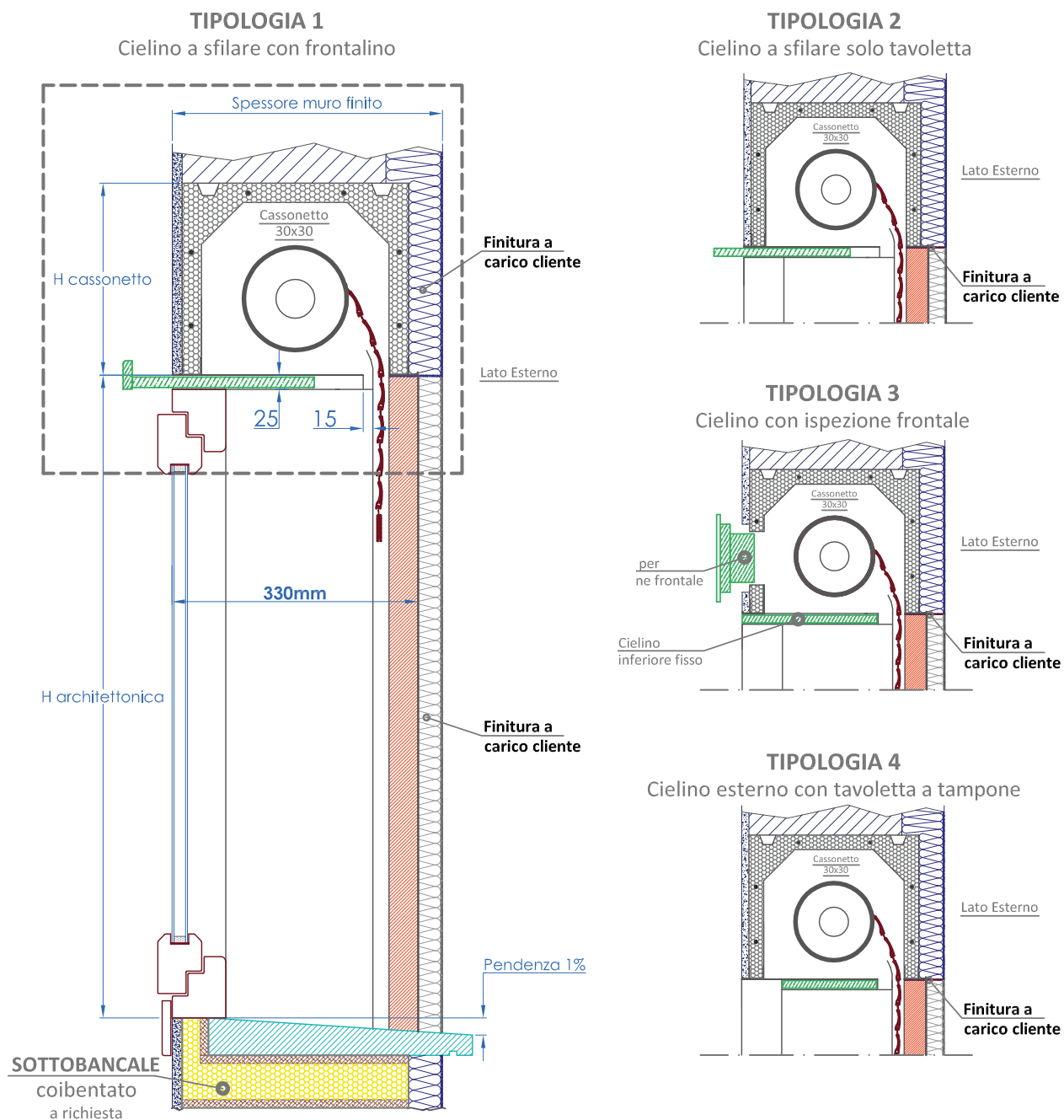

TRASMITTANZA TERMICA	POTERE FONOISOLANTE
Cassonetto: $U=1,1 \text{ W/m}^2 \text{ K}$	$R_w = 43 (-1;-6) \text{ Db}$ telo alzato $R_w = 45 (-1;-6) \text{ Db}$ telo abbassato
Prova di invecchiamento nel tempo:	Superata Certificato nr. 55 0036 10/2 rilasciato da TÜV Rheinland